

Reuter Centrifugal Air Sampler: Measurement of Effective Airflow Rate and Collection Efficiency

J. M. MACHER* AND M. W. FIRST

Department of Environmental Health Sciences, School of Public Health, Harvard University, Boston, Massachusetts 02115

Received 20 October 1982/Accepted 29 March 1983

Incorrect calculation of effective air sampling rate and disregard of differences in collection efficiency among samplers can lead to false conclusions about the usefulness of samplers for measuring concentrations of airborne microorganisms.

Aerosol samplers differ widely in their collection efficiencies for various particle sizes. The size of bacteria-laden particles determines how they move in response to a separating force field and the efficiency with which they are captured by collection devices. The evaluation of microbiological air sampling devices is not an easy undertaking, and in most cases, therefore, the utility of new instruments is assessed by comparative tests with widely used and well-characterized standard samplers.

To correctly evaluate the capability of a sampler to draw in, retain, and preserve the viability of specific organisms at a given location, the sampler must be calibrated against measured concentrations of known organisms. A number of devices have been used to generate controlled concentrations of living organisms from pure cultures for such measurements. However, not all cells in a culture are alive, and additional losses in viability occur during dispersion of the cells as an aerosol (usually by compressed air atomization), while the cells are airborne, and when the cells are subjected to the collecting forces of a sampling device. Comparing two samplers in uncontrolled natural environments fails to reveal the absolute collection efficiency of either sampler relative to the number of collectable organisms capable of multiplying, especially in the case of less hardy vegetative cells.

Collection by particle size can be determined with nonviable particles or organisms of known size by measuring retention using criteria other than viability. Such methods include the use of optical counters capable of sampling and analyzing airborne particles and the use of tracers such as fluorescent dyes, with results evaluated by counting or total mass techniques. It is puzzling why air samplers of viable organisms have not been characterized routinely by their particle size retention characteristics on the basis of aerodynamic equivalent diameters; the methods

for obtaining these data are well known and reasonably simple to perform. Were this information available for all such instruments, it would be possible to compare one with another to determine which better preserves viability. Ultimately, characteristics for recovery of viable organisms could be expressed on an absolute scale.

Unfortunately, quantitative results are difficult to verify if the volume of air sampled is unknown, owing to difficulties in measuring the airflow rate in a manner that does not affect the free intake of air, as is the case with the Reuter centrifugal air sampler (RCS). Under these conditions, investigators are faced with three unknowns—sampling rate, retention characteristics, and the effects of these factors on the viability of the collected microorganisms—making any hope of obtaining quantitative results unrealistic.

Recognition of the uncertainties associated with the use of uncalibrated devices for sampling unknown aerosols in natural environments makes it easier to understand why divergent and often contradictory results are reported by investigators measuring the collection efficiency of instruments of identical design.

Placencia et al. (2) operated an RCS (Hycon, Miami, Fla.) side by side with a rotating slit-to-agar sampler (model 200, Mattson-Garvin Co., Maitland, Fla.) and reported that the RCS recovered a greater total number of bacteria from equal volumes of air. The authors operated the RCS according to the directions of the manufacturer and verified that the RCS impeller was operating at the correct revolutions per minute.

According to the manufacturer, this rate of impeller revolution produces an effective sampling rate of 40 liters/min. However, the RCS uses a single opening for air intake and discharge, making it difficult to discriminate between the two airstreams when attempting to quantify flow rates and measure particle con-

tents of the two airstreams by customary methods. To test the performance of the RCS, it was necessary to design an inlet adapter that would clearly separate the inflow and exhaust airstreams without altering the normal airflow patterns of the instrument. An elongated version of the inlet adapter is shown in Fig. 1.

With the adapter in place, the total flow drawn into the RCS was measured by withdrawing air from a 180-liter Douglas bag that imposed no significant resistance to airflow. The volume of air in the bag was measured with a spirometer before and after drawing a sample at 30 s, and the difference was used to evaluate the total sampling rate for the RCS. With the inlet adapter, it was 210 ± 27 liters/min. This is not greatly different from the calculated total sampling rate of the manufacturer: 280 liters/min for an unmodified sampler. However, the manufacturer published an effective sampling rate or separation volume of 40 liters/min for 4- μm particles, a value derived from an attempt to reconcile the observed number of bacteria collected from air with measurements involving airflow direction, air velocity, and available collecting surface area. From the standpoint of the manufacturer, it is preferable to state that the instrument removes 100% of 4- μm particles from a 40 liter/min fraction of the total sampled air than to state that the instrument is 14% (40/280) efficient for collecting 4- μm particles, based on the total airflow induced into the sampling chamber.

Our approach to determining the retention efficiency of the RCS (convertible into effective sampling rate, the manufacturer's term) was to measure the percentage of unit density particles over a range of sizes, including the expected

range of airborne microorganisms, removed from the total sampled air volume. Aerosols of polystyrene latex (PSL) spheres (Dow Chemical Co., Indianapolis, Ind.) were generated from a water suspension with a no. 40 nebulizer (The DeVilbiss Co., Somerset, Penn.). An elongated version of the air inlet adapter used to measure airflow was fitted with a bell mouth opening and enclosed in a cylindrical container (diameter, 13 cm) attached to the RCS (Fig. 1). This arrangement completely separated the airstreams entering and exiting the RCS. All air leaving the modified RCS was discharged through a 15-cm duct, and a measured portion was withdrawn through a membrane filter (0.45- μm pore size; Millipore Corp., Bedford, Mass.) considered an absolute (100% efficiency) particle collector. After sampling, sections of the filter were mounted on a glass slide for examination under a light microscope, and all particles were counted in carefully measured fields. By applying suitable factors to account for the total air volume discharged from the RCS, the fraction collected on the membrane filter, and the fraction of the total membrane filter represented by the number of microscope fields examined, the total number of PSL spheres penetrating the RCS was calculated. PSL spheres retained by the RCS were collected on a strip of plastic coated with microscope immersion oil and covered with a strip of membrane filter paper. The number of collected spheres was determined in the same manner as that used to analyze the membrane filter samples of air discharged from the RCS.

The collection efficiency of the RCS with the inlet adapter was calculated as the ratio of the number of particles collected by the RCS and

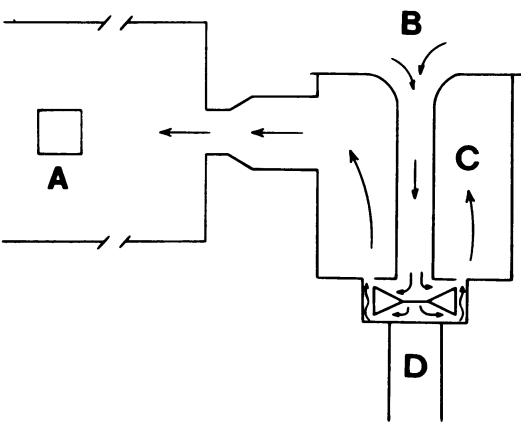

FIG. 1. Cross section of RCS with inlet adapter to separate inflow and discharged air. (A) Membrane filter; (B) aerosol inlet; (C) air discharge plenum; (D) RCS.

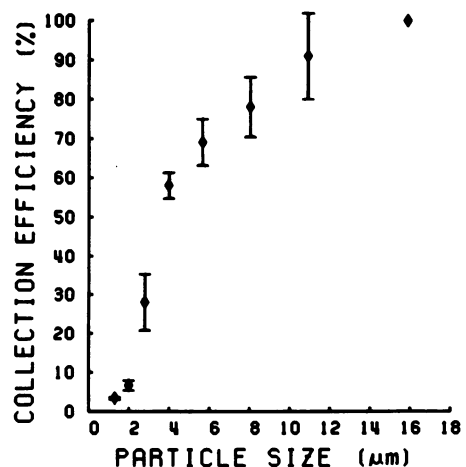

FIG. 2. Collection efficiency of the RCS. Vertical bars represent standard deviations.

the total number entering the RCS, i.e., the number collected by the RCS plus the number collected in the discharged air, with suitable adjustments for the different collecting surface areas and volumes of air sampled.

Improved collection efficiency was seen with increasing particle size (Fig. 2). No particles larger than 15 μm were seen on the downstream filter, whereas particles smaller than 1 μm passed through the modified RCS without significant retention. Because the specific gravity of the PSL spheres is close to 1, the particle size data of Fig. 2 can be interpreted as aerodynamic equivalent diameters. The effective sampling rate, calculated by the rating method of the manufacturer, changed rapidly over the range of particle sizes representing respirable microorganisms known to remain airborne for appreciable periods of time (Fig. 2).

Our results agree with those of Clark et al. (1)

and indicate that the RCS is not the sampler of choice for quantitative estimates of microbiological aerosol concentrations, except when the particle size of the aerosol is known and the collection efficiency for that size particle has been measured or when the aerodynamic equivalent diameters of the particles in the aerosol are known to be predominantly larger than 5 μm . The RCS has proven useful for gathering qualitative information and for long-term monitoring programs in which all readings will be made with the same sampler.

LITERATURE CITED

1. Clark, S., V. Lach, and O. M. Lidwell. 1981. The performance of the Biotest RCS centrifugal air sampler. *J. Hosp. Infect.* 2:181-186.
2. Placencia, A. M., J. T. Peeler, G. S. Oxborrow, and J. W. Danielson. 1982. Comparison of bacterial recovery by Reuter centrifugal air sampler and slit-to-agar sampler. *Appl. Environ. Microbiol.* 44:512-513.